

Xi-1152/64 X-Array Install™

Two-Way, Full-Range, Sound-Reinforcement System

- Ring-Mode Decoupling (RMD™)
- Substantially improved vocal range performance
- New EVX-155 woofer with 3-dB additional LF output, increased power handling/ lower distortion
- New DH6 compression driver
- New HF horn (60° x 40°) fully rotatable for vertical or horizontal suspension

Description

Introducing a family of advanced sound reinforcement products for everyone who desires the sound quality of Electro-Voice's X-Array™ touring systems. X-Array Install™ is the ideal choice for small-to-medium array configurations and fixed installations of any size.

Inspired by the most demanded features of EV's acclaimed X-Array™ touring systems, the X-Array Install™ series incorporates a potent combination of very high output, medium- to long-throw "cells," and Ring-Mode Decoupling (RMD™).

RMD™

Ring-Mode Decoupling is the same advanced technology built into the X-Array™ touring series. RMD™ produces substantially improved tonal character and fidelity whether operated at low or extremely high sound pressure levels. RMD™ attacks time domain "ringing modes" at their sources. Mechanical solutions resolve mechanical issues, and acoustical solutions address acoustical modes found in all sound reinforcement systems. The combination of each RMD™ technique provides improved tonal character and fidelity at increasing drive levels. The

result is clear, even sound quality with vastly improved intelligibility.

DH6 Large-Format Driver

All multiway systems in the series are equipped with EV's newly developed DH6 large-format compression driver. The DH6 compression driver incorporates many RMD™ techniques, including a new titanium diaphragm with increased internal mechanical damping that provides clear, intelligible upper vocal performance. The phase plug placed close to the diaphragm improves acoustic damping and boosts output in the 10-to 20-kHz range.

Magnetics

Mid-bass and high-frequency drivers in X-Array Install™ products use ferrite magnetics instead of the neodymium magnetics used in X-Array™ touring systems. While neodymium drivers provide unmatched output capabilities, the advanced RMD™ technology used in X-Array Install™ produces world class sound reinforcement at very high levels.

Applications

The Xi-1152/64 loudspeaker system is ideal for any professional touring or installation application requiring accurate, high-level

sound reinforcement. Because of the unique performance capabilities featured in this system, the Xi-1152/64 offers extremely wide-range music reproduction as well as accurate vocal coverage and maximized intelligibility.

The Xi-1152/64 is recommended for applications requiring full bandwidth down to 50 Hz. Where very high levels of deep bass are required, maximum performance may be achieved with the addition of the Xi-1191 (single 18-inch subwoofer). This subwoofer system features the EVX-180B 18-inch subwoofer and is designed to be used with associated processors.

Power-Handling Test

Electro-Voice components and systems are manufactured to exacting standards to ensure reliability in continuous use in arduous real-life conditions. Besides utilizing industry-standard power tests, extreme in-house power tests which push the performance boundaries of the loudspeakers are also performed for an extra measure of reliability. The Xi-1152/64 systems are rated per ANSI/EIA RS-426-A Loudspeaker Power Rating, Full Range Test, which uses a shaped-random-noise signal to simulate typical music to test the mechanical and thermal capabili-

X-Array Install™ Xi-1152/64 Loudspeaker System

ties of the loudspeakers. The Dx34 digital electronic unit was used to provide the necessary crossover filters and equalization during power testing. Specifically, the Xi-1152/64 passes the ANSI/EIA RS-426-A power test with the following test parameters:

Low-Frequency Section:

$P_{E(MAX)}$:	600 watts
Test Voltages:	58.7 volts rms
	117.4 volts peak
$R_{SR}(1.15 R_E)$:	5.75 ohms

High-Frequency Section:

$P_{E(MAX)}$:	75 watts
Test Voltages:	28.46 volts rms
	57.8 volts peak
$R_{SR}(1.15 R_E)$:	10.8 ohms

Crossover, Equalization and Time-Delay Controller

The Xi-1152/64 speaker system and variants are designed as an integrated package that utilizes any of the following controllers: Merlin ISP100, Electro-Voice Dx34 digital crossover system or Klark-Teknik DN8000. Optimal performance of the Xi-1152/64 speaker system can only be assured when using the above referenced controllers.

All controllers used with the Xi-1152/64 feature a 1,480-Hz crossover frequency utilizing 24-dB-per-octave Linkwitz-Riley filters. All contain fixed time delay and equalization for optimum performance of the Xi-1152/64.

Electrical Connection and System Wiring

Electrical connections to the Xi-1152/64 are made on the back of the enclosure via a 4-pin connector. There are two connectors on the input panel to allow paralleling of other Xi-1152/64 systems. The Neutrik Speakon® NL4MPP is used for both connections. The pin assignments are as follows:

- Pin 1+: LF(+)
- Pin 1-: LF(-)
- Pin 2+: HF(+)
- Pin 2-: HF(-)

The wiring diagram of the loudspeaker system is shown in Figure 7. The electrical im-

pedance is shown in Figure 6.

Amplifier Requirements

Power amplifiers with the following ratings are recommended for use with the Xi-1152/64 speaker systems:

LF: 600-1,200 watts continuous into 8 ohms

HF: 125-250 watts continuous into 8 ohms

Xi-1152/64 speakers may be paralleled only with other Xi-1152/64 speakers if the amplifier is capable of delivering full power at the lower impedances. The use of amplifiers with lower power ratings is acceptable; however, the full-power capabilities of the Xi speakers will not be realized. The use of amplifiers with significantly higher power ratings will generate maximum dynamic range and fidelity, but care must be utilized for longer duration signals as mechanical and thermal damage are possible in the system. Under certain circumstances, higher rated amplifiers are acceptable. It is acceptable to drive the Xi-1152/64 speakers with a stereo power amp utilizing one channel to drive the low frequencies and the other channel to drive the high frequencies. See owner's manuals on various controllers for appropriate settings.

Flying the X-Array Install™ Systems

A manual entitled the *X-Array Install™ Flying Manual* is available from Electro-Voice, and is included with each flying Xi loudspeaker system. A brief introductory overview is included here. The *X-Array Install™ Flying Manual* should be consulted for complete structural specifications and detailed information on safely suspending and using the Xi systems.

The Xi systems incorporate a unique, two-point flying system that permits a wide range of vertical angle adjustment, and offers maximum flexibility in array design for both touring sound and permanent installations. The quick release, aircraft-rated, heavy-duty L-track-type hardware design allows arrays of loudspeakers to be assembled (and disassembled) very quickly, and offers such flexibility in the vertical angling of cabinets that pull-up points are usually unnecessary. Furthermore, all of the flying Xi loudspeaker models include the same rigging hardware,

allowing different models to be mixed as necessary throughout an array.

The working-load limit (for an 8:1 safety factor) for each rigging point on the Xi loudspeaker enclosure is 227 kg (500 lb) for a 0° pull angle and 170 kg (375 lb) for a 90° pull angle when used with the New Haven NH32101-2S double-stud fitting, and 113 kg (250 lb) when used with the New Haven NH8192-2 or Ancra 42546-10 single-stud fittings with locking pins. The working-load limit (for an 8:1 safety factor) for the overall enclosure is 340 kg (750 lb). (Consult the *X-Array Install™ Flying Manual* for specific structural ratings and limitations.) The enclosures may be oriented with the rigging track on the sides of the enclosure, or on the top and bottom, and may be daisy-chained together as long as the safety factor is 8:1 or greater, and local regulations are met. For fire safety and additional structural strength in both flying orientations, top-to-bottom and side-to-side metal straps link the rigging track inside the enclosure. Electro-Voice offers a line of flying-hardware accessories for use with the Xi loudspeaker systems. All associated rigging is the responsibility of others.

CAUTION: The X-Array Install™ loudspeaker system should be suspended overhead only in accordance with the procedures and limitations specified in the *X-Array Install™ Flying Manual* and manual update notices.

Field Replacement

The Xi-1152/64 was designed for expedient field service. Removing the woofer bolts allows the woofer to be easily removed. Removing the horn-mounting screws allows access to the compression driver, both through the horn and woofer baffle cutouts. A woofer failure will require replacement of the entire driver. In the case of a compression driver failure, a diaphragm assembly replacement kit with instructions is available. If desired, the complete driver may be returned for service.

The following replacement parts are available from Electro-Voice Service in Buchanan, Michigan:

LF: Complete woofer: EV Part No. 815-3075

HF: Diaphragm kit; EV Part No. 84233-XX

X-Array Install™ Xi-1152/64 Loudspeaker System

Architects' and Engineers' Specifications

The loudspeaker system shall be a two-way biamped system with performance controlled by a variety of dedicated electronic control units. The loudspeaker system shall have a 15-inch, low-frequency, direct-radiating driver with an 8-ohm, 4-inch voice coil constructed of aluminum wire, and shall be capable of a 600-watt shaped pink-noise signal with a 6-dB crest factor for 8 hours (as per ANSI/EIA RS-426-A 1980 standard). The loudspeaker system shall have a 50.8-mm (2-inch) exit compression driver mounted on a high-frequency horn. The compression driver shall have 76.2-mm (3.0-inch) diameter, .0015-inch thick titanium dome and an 16-ohm nominal, 76.2-mm (3.0-inch) diameter voice coil constructed of aluminum wire, and which shall be capable of handling a 75-watt, 1,480-to 20,000-Hz pink-noise signal with a 6-dB crest factor for 8 hours (as per EIA RS-426-A 1980 standard). The high-frequency horn shall be of the constant-directivity type and fully rotatable and shall produce a nominal horizontal beamwidth (6-dB-down angle) of 60° from 2,000 to 20,000 Hz, and a nominal vertical beamwidth of 40° from 1,600 to 20,000 Hz. The loudspeaker system enclosure shall be constructed of 18-mm thick 13-ply birch plywood, trapezoidal in shape, forming a 30° wedge, and shall have a vinyl-clad steel-grille system.

The Xi-1152/64 system shall be used with recommended control systems and shall have a two-way crossover circuit with fourth-order Linkwitz-Riley filters, equalization, time delay and protection circuitry. When used with the electronic control unit, the loudspeaker system shall have a flat on-axis frequency response from 50 to 16,000 Hz. The loudspeaker enclosure dimensions shall be 759 mm (29.88 inches) high, 450 mm (17.73 inches) wide and 413 mm (16.26 inches) deep and shall weigh 40.7 kg (89.5 lb). The system shall incorporate a two-point rigging system that will accept New Haven NH32101-2 double-stud ring fittings and the New Haven NH8192-2.5 and Ancva 4254C-10 single-stud fittings.

The loudspeaker shall be Electro-Voice Xi-1152/64.

Uniform Limited Warranty

Electro-Voice products are guaranteed against malfunction due to defects in materials or workmanship for a specified period, as noted in the individual product-line statement(s) below, or in the individual product data sheet or owner's manual, beginning with the date of original purchase. If such malfunction occurs during the specified period, the product will be repaired or replaced (at our option) without charge. The product will be returned to the customer prepaid.

Exclusions and Limitations: The Limited Warranty does not apply to: (a) exterior finish or appearance; (b) certain specific items described in the individual product-line statement(s) below, or in the individual product data sheet or owner's manual; (c) malfunction resulting from use or operation of the product other than as specified in the product data sheet or owner's manual; (d) malfunction resulting from misuse or abuse of the product; or (e) malfunction occurring at any time after repairs have been made to the product by anyone other than Electro-Voice Service or any of its authorized service representatives.

Obtaining Warranty Service: To obtain warranty service, a customer must deliver the product, prepaid, to Electro-Voice Service or any of its authorized service representatives together with proof of purchase of the product in the form of a bill of sale or receipted invoice. A list of authorized service representatives is available from Electro-Voice Service at 600 Cecil Street, Buchanan, MI 49107 (800/234-6831 or FAX 616/695-4743).

Incidental and Consequential Damages Excluded: Product repair or replacement and return to the customer are the only remedies provided to the customer. Electro-Voice shall not be liable for any incidental or consequential damages including, without limitation, injury to persons or property or loss of use. Some states do not allow the exclusion or limitation of incidental or consequential damages so the above limitation or exclusion may not apply to you.

Other Rights: This warranty gives you specific legal rights, and you may also have other rights which vary from state to state.

Electro-Voice Speakers and Speaker Sys-

tems are guaranteed against malfunction due to defects in materials or workmanship for a period of five (5) years from the date of original purchase. The Limited Warranty does not apply to burned voice coils or malfunctions such as cone and/or coil damage resulting from improperly designed enclosures. Electro-Voice active electronics associated with the speaker systems are guaranteed for three (3) years from the date of original purchase. Additional details are included in the Uniform Limited Warranty statement.

Electro-Voice Accessories are guaranteed against malfunction due to defects in materials or workmanship for a period of one (1) year from the date of original purchase. Additional details are included in the Uniform Limited Warranty statement.

Electro-Voice Flying Hardware (including enclosure-mounted hardware and rigging accessories) is guaranteed against malfunction due to defects in materials or workmanship for a period of one (1) year from the date of original purchase. Additional details are included in the Uniform Limited Warranty statement.

X-Array Install™ Xi-1 152/64 Loudspeaker System

Figure 1— Polar Response

The directional response of the system was measured in an anechoic environment at a distance of 6.1m (22 feet) using 1/3-octave-filtered pink noise with a full spherical measurement system. The DN8000 digital electronic unit was used to provide the necessary crossover filters, equalization and time delay. The polar response of the loudspeaker system at selected 1/3-octave frequencies is shown. The selected frequencies are representative of the polar response of the system.

X-Array Install™ - 1 152/64 Loudspeaker System

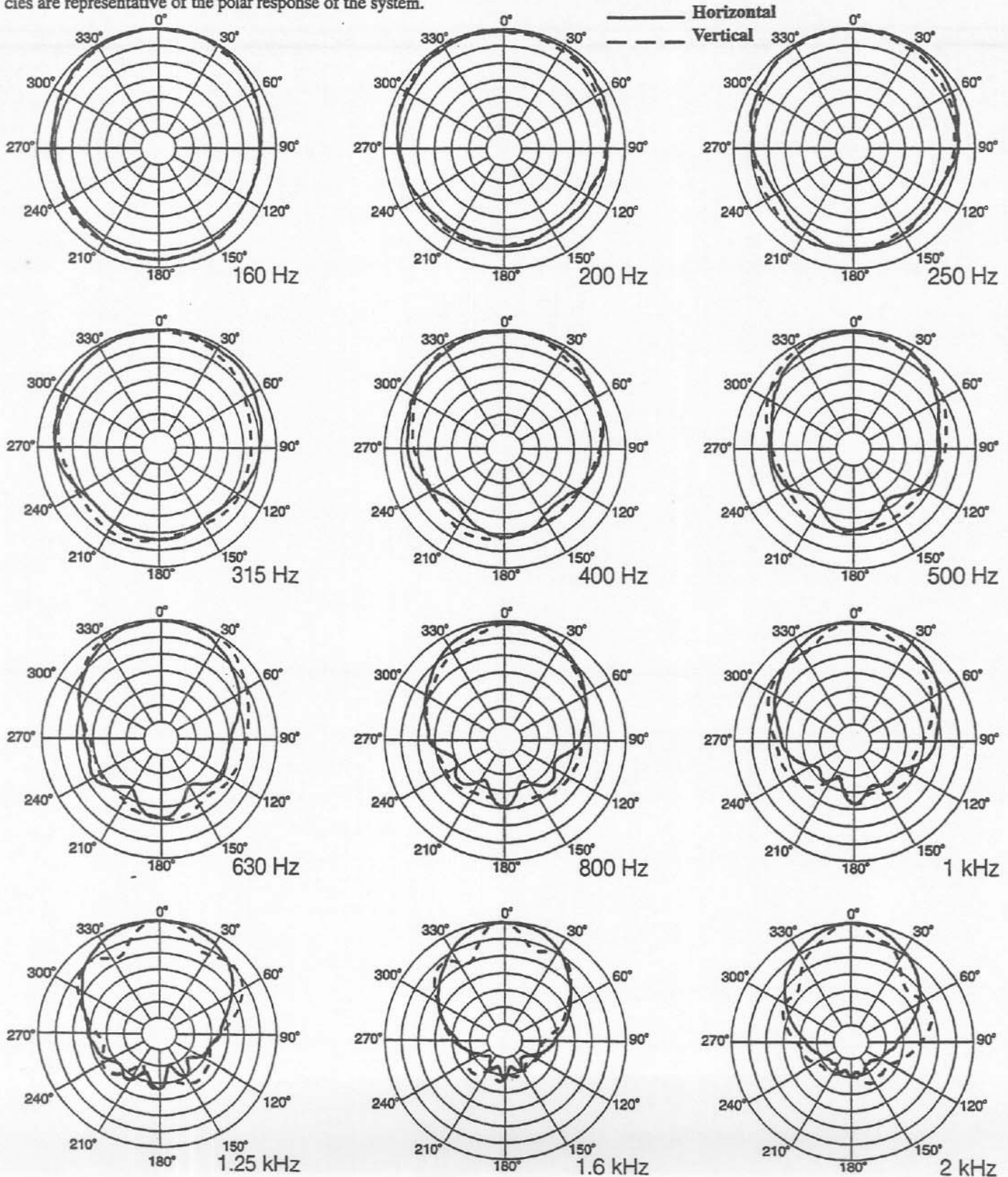

X-Array Install™ Xi-1 152/64 Loudspeaker System

X-Array Install™ Xi-1 152/64 Loudspeaker System

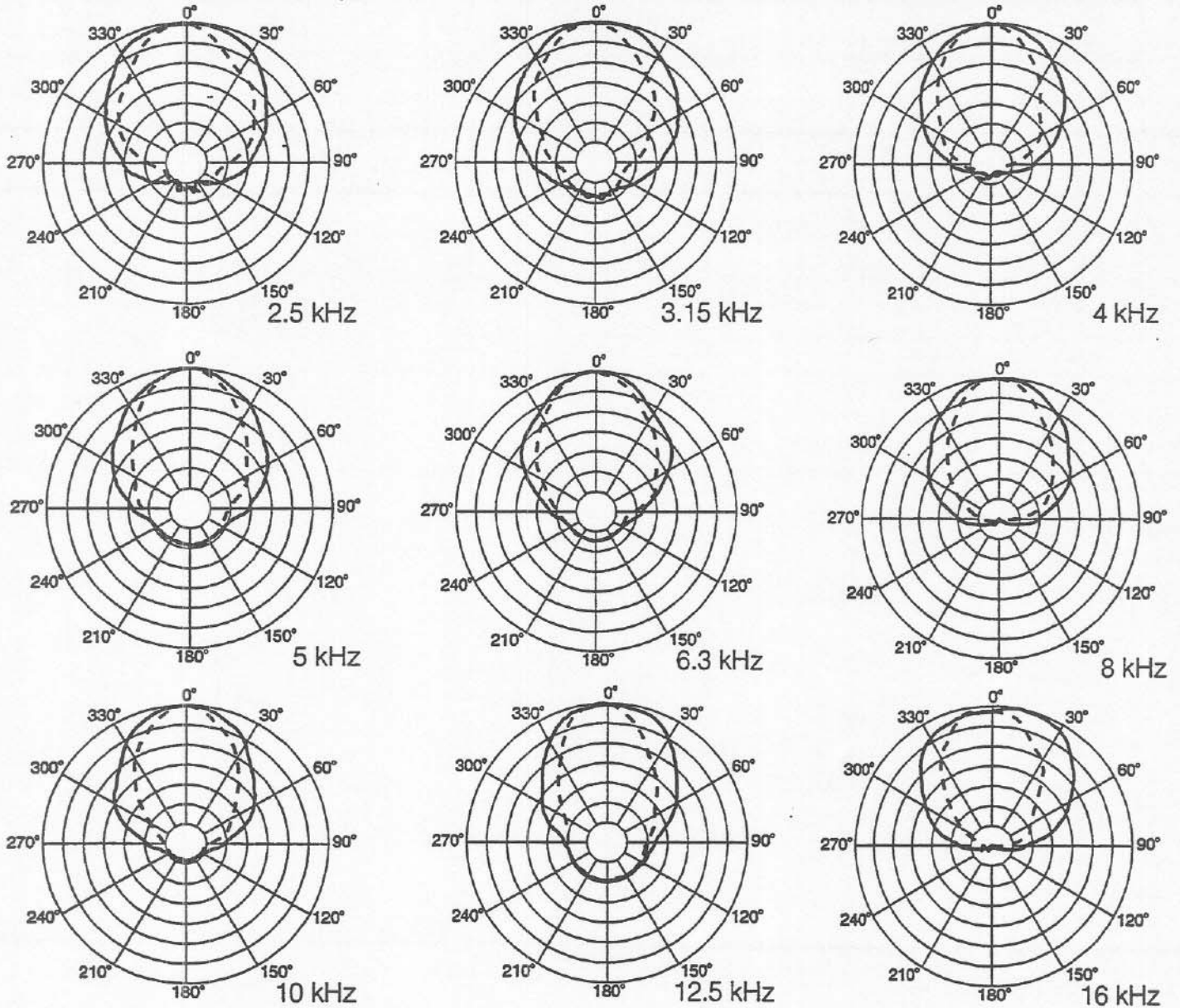
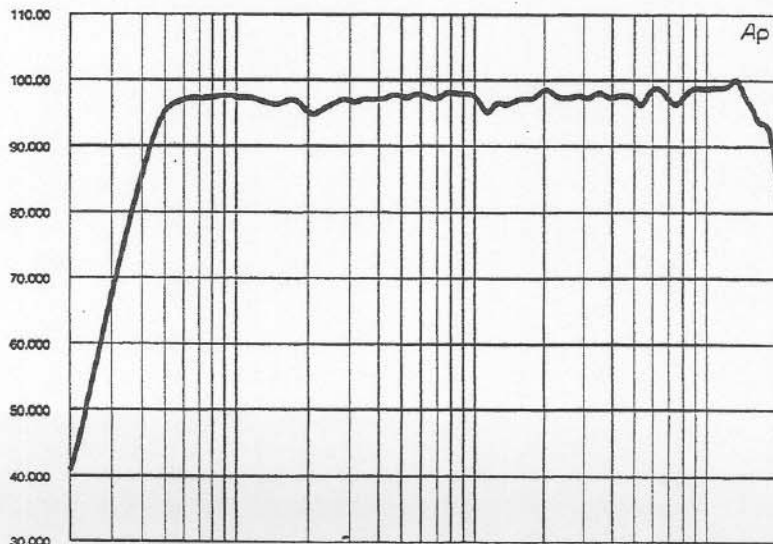

Figure 2—Frequency Response

The frequency response of the system was measured on axis in the farfield in an anechoic environment using a swept sine-wave signal. The DN8000 digital electronic unit was used to provide the necessary cross-over filters, equalization and time delay. One watt of power (2.83 volts rms at 250 Hz) was applied to the midband of the low-frequency section. The sound-pressure level was normalized for an equivalent one meter distance.



X-Array Install™ Xi-1 152/64 Loudspeaker System

Figure 3—Beamwidth

The beamwidth of the system, (i.e., the included horizontal and vertical coverage angles at the 6-dB down point) was measured with a full spherical measurement system as described in "Polar Response."

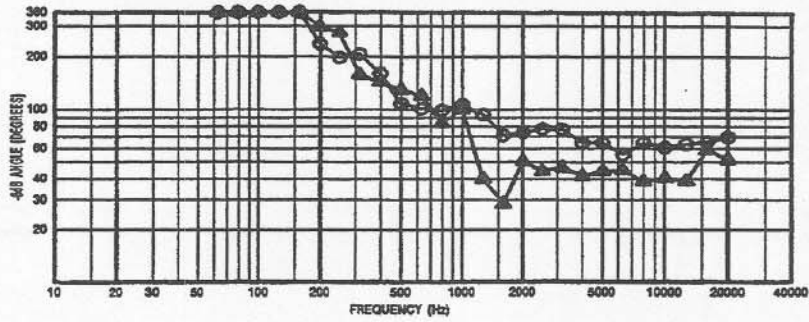

Figure 4—Directivity

The directivity index, D_p and directivity factor, R_0 (Q), of the system were measured with a full spherical measurement system as described for the "Polar Response."

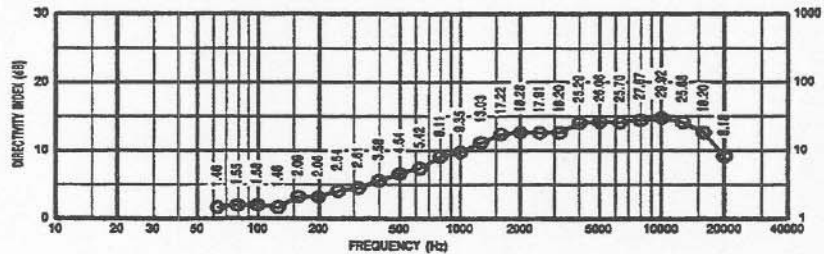
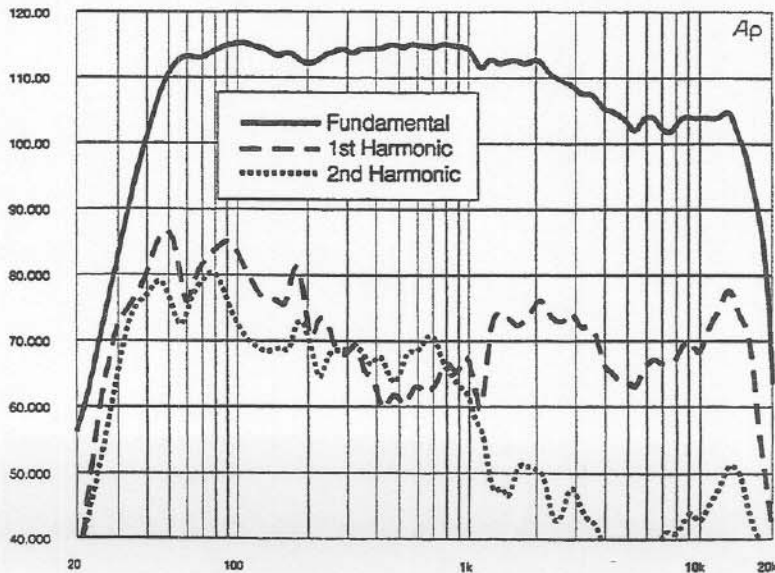

Figure 5—Distortion

Distortion for the system was measured on axis in the field in an anechoic environment with an input signal that would result in a sound-pressure level of 115 dB at one meter. The DN8000 digital electronic unit was used to provide the necessary crossover filters, equalization and time delay. A frequency spectrum typical of close-mic'd rock music was employed. The sound-pressure level was normalized for an equivalent one-meter distance. Plots of second and third harmonic distortion are shown referenced to the fundamental.



X-Array Install™ Xi-1 152/64 Loudspeaker System

Figure 6—Impedance

The impedance of each frequency band of the system was measured in an anechoic environment.

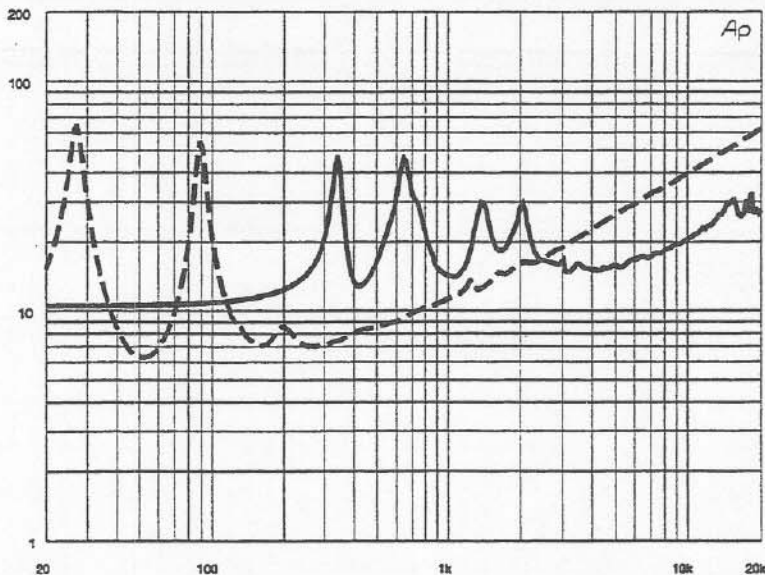
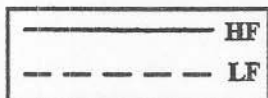

Figure 7—Wiring Diagram

The wiring diagram of each frequency band of the system is shown.

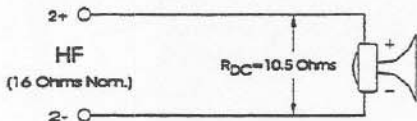
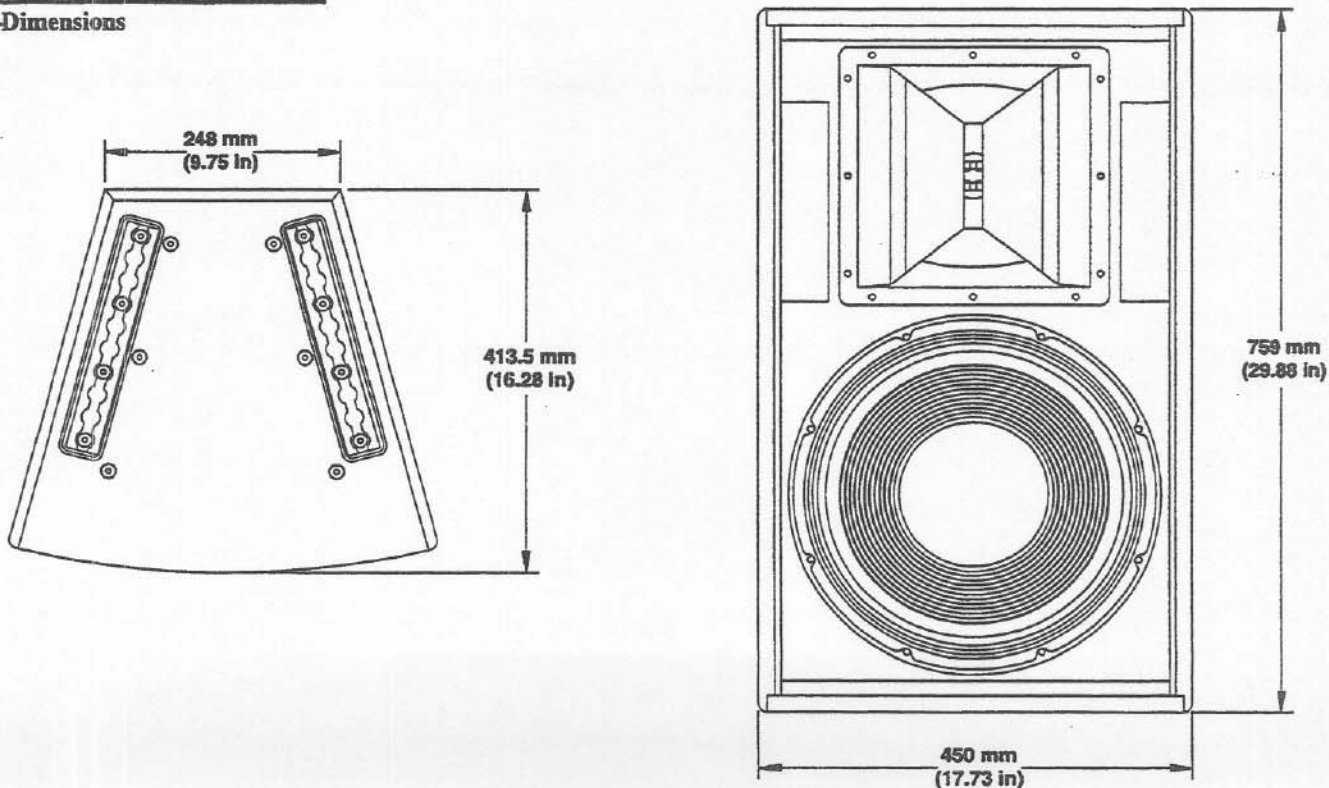

Figure 8—Dimensions



X-Array Install™ Xi-1 152/64 Loudspeaker System

Specifications

Frequency Response (measured in far field, calculated to one meter on axis, swept sine wave, one watt into LF section 2.83 V at 250 Hz, anechoic environment; see Figure 2):

50-16,000 Hz

Crossover Frequency:

1,500 Hz

Efficiency, LF/HF:

4.2/25 %

Maximum Long-Term-Average Power-Handling Capacity (per ANSI/EIA RS-426-A 1980), LF/HF:

600/75 watts

Maximum Long-Term-Average

Midband Acoustic Output, LF/HF:

25/19 acoustic watts

Sensitivity (SPL at one meter, indicated input power, anechoic environment, average level), LF/HF,

1/1 watt:

98.0/113.0 dB

300/75 watts:

122.8/131.8 dB

Beamwidth (angle included by 6-dB-down points on polar responses, indicated one-third-octave bands of pink noise; see Figures 1 and 3),

Horizontal, 1,200-16,000 Hz:

60° (+40°, -5°)

Vertical, 1,200-16,000 Hz:

40° (+28°, -15°)

Directivity Factor, $R_p(Q)$, 1,200-16,000 Hz Average (see Figure 4):

21.9 (+8.0, -8.9)

Directivity Index, D_p , 1,200-16,000 Hz Average (see Figure 4):

13.4 dB (+1.3 dB, -2.3 dB)

Distortion (115 dB SPL at one meter, shaped spectrum; see Figure 5),

Second Harmonic,

100 Hz:

2.5 %

500 Hz:

0.2 %

2,000 Hz:

1.4 %

5,000 Hz:

1.1 %

Third Harmonic,

100 Hz:

0.7 %

500 Hz:

0.3 %

2,000 Hz:

<0.1 %

5,000 Hz:

<0.1 %

Transducer Complement,

HF:

DH6 driver, HP64S 60° x 40° horn

LF:

EVX-155 15-in. woofer

Impedance (see Figure 6),

Nominal, LF/HF:

8/16 ohms

Minimum, LF/HF:

6.3/14.0 ohms

Input Connections:

Two Neutrik NL4MPR Speakon® connectors paralleled

Recommended Amplifier Power,

HF:

125-250 watts

LF:

600-1,200 watts

Enclosure Construction,

Enclosure Shell:

18-mm, 13-ply birch plywood

Finish:

Black textured paint

Grille:

Vinyl-coated steel with foam

Rigging:

Two-point heavy-duty L-track system, accepts New Haven NH32102-2 double-stud fittings, or New Haven NH8192-2S or Ancra 42546-10 single-stud fittings with safety pins

Dimensions,

Height:

759 mm (29.88 in.)

Width (front):

450 mm (17.73 in.)

Width (back):

248 mm (9.75 in.)

Depth:

413 mm (16.28 in.)

Angle:

30° wedge

Net Weight:

40.8 kg (90 lb)

Shipping Weight:

43.1 kg (95 lb)

Electro-Voice®

600 Cecil Street, Buchanan, MI 49107

800/234-6831, 616/695-6831, 616/695-1304 Fax

©Telex Communications, Inc. 1998 • Litho in U.S.A.